

TECHNICAL DATASHEET



TRANSITION ADAPTOR PE-PE

03 Update - 06/2023

TECHNICAL DATA

Article No	001 117 6211 0063
d (mm)	63
R (inch)	2"
le (mm)	49
Z (mm)	85
s (mm)	5,8
Weight (Kg)	0,170
Box Quantity (pcs)	60
Box Dimension (pcs)	55x30x36

IDENTIFICATION OF PRODUCT

D	63x2"
PN	10
RAW METARIAL	PE 100
PRESSURE CLASS	10 Bar Water
TRADEMARK	NTG
EXECUTION	Injection Moulded
STANDARD	EN 12201-3

INJECTION MOULDED

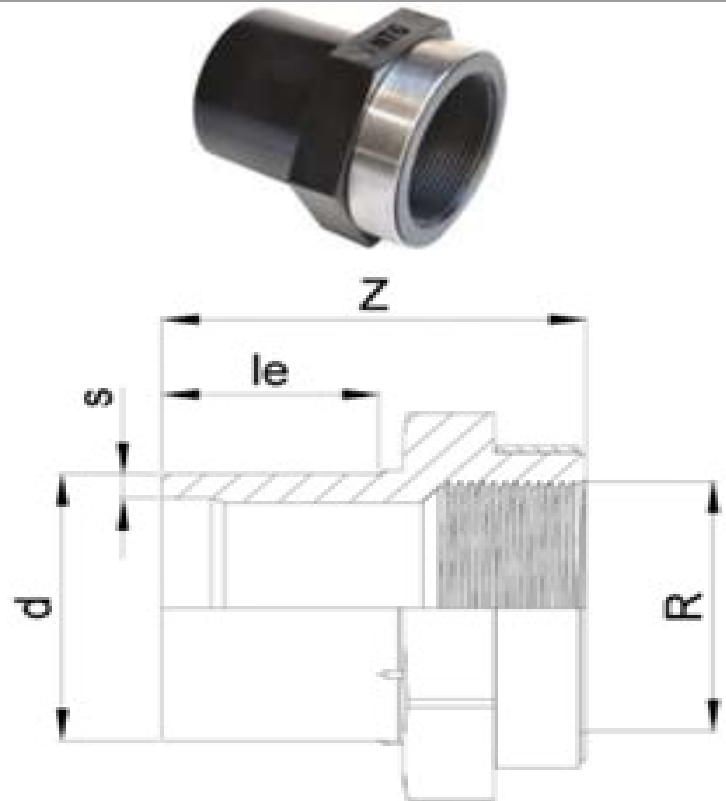

SPECIFICATION

Long Spigot
Reinforcing ring stainless

Tolerance on diameters and thickness according to the standards. The other dimensions are specialized. Tolerance $\pm 5\%$. NTG PLASTIK reserves all the right to change any information without giving prior notice. The production, distribution and utilization of this document without explicit authorization is prohibited.

Fr 161 Rev 00